

Instruction Manual



Fistreem III

**4 litre per hour double (Bi-) distiller
8 litre per hour single distiller**



READ BEFORE USE!

This Manual contains different levels of warnings and cautions in order to ensure you are alerted to any potential hazards when installing or operating the equipment. These are categorised as follows:

| | |
|-----------------|---|
| WARNING: | APPLIES WHEN THERE IS A POSSIBILITY OF PERSONAL INJURY |
|-----------------|---|

CAUTION: Applies when there is a possibility of damage to the equipment.

NOTE: Alerts the user of the manual to pertinent facts and conditions.

Symbols Various symbols are used on the product as follows:



Electrical Safety



Reservoir Float Switch Connection



Earth Symbol

NEW EQUIPMENT WARRANTY

Seller warrants that its products are free from defects in materials and workmanship (under normal conditions of use and service) for the period specified on the warranty card enclosed with the product from date of shipment to the original purchaser and will conform to the contract specifications or such other specifications which constitute technical improvements to the product.* The exclusive remedy of buyer in the event of a breach of the foregoing warranty is to the replacement or repair (at seller's option) of any defective product. No goods shall be returned to seller for repair or replacement pursuant to this warranty without prior written approval. All cleaning, decontamination, and shipping costs shall be the sole responsibility of the buyer together with any damage to the goods that might occur in transit to or from seller. Under no circumstances does seller's responsibility or warranty extend to products other than those manufactured or distributed by seller; nor does seller's liability extend to any products, articles or parts which are furnished by buyer or obtained from other manufacturers or suppliers at buyer's request and/or in accordance with buyer's specifications. In the event that seller is unwilling or unable to repair or replace any defective or nonconforming product due to change in technical standards, technical modifications, nonavailability of material or parts, or any other reason, buyer shall be entitled to a return of the purchase price paid for such product, as its sole and exclusive remedy. Seller assumes no responsibility whatsoever for the accuracy of designs, specifications or materials furnished or specified by buyer.

THE WARRANTIES SET FORTH HEREIN ARE IN LIEU OF ANY AND ALL OTHER WARRANTIES, EXPRESS OR IMPLIED, INCLUDING THE WARRANTIES OF MERCHANTABILITY AND FITNESS. THE BUYER ACKNOWLEDGES THAT IT IS NOT RELYING ON THE SELLER'S SKILL OR JUDGEMENT TO SELECT OR FURNISH GOODS SUITABLE FOR ANY PARTICULAR PURPOSE AND THAT THERE ARE NO WARRANTIES WHICH EXTEND BEYOND THOSE SET FORTH HEREIN. IN NO EVENT SHALL SELLER BE LIABLE FOR BUYER'S LOSS OF PROFIT OR INCIDENTAL, CONSEQUENTIAL OR SPECIAL DAMAGES OF ANY KIND.

Please visit www.labstrong.com to register your product

Read This Before Use!

FISTREEM III

8 & 4BD STILL TAP & PRE-TREATED FEED

April 2010

Instruction Manual part. No. LT857X2LS

MANUAL CONTENTS

| | Page |
|---------------------------------|----------------|
| Warnings, Cautions, Notes | 3 |
| Health & Safety at Work | 4 |
| Technical Support and Warranty | 4 |
| Manual Contents | 5 |
| Diagrams | 6, 7, 8, 9 |
| Description | 10 |
| Care of Product | 10 |
| Glassware Safety | 11 |
| Electrical Safety | 11 |
| Pre-installation | 12 |
| Positioning | 13 |
| Unpacking | 13 |
| Installation Procedures | 14 |
| Door removal | 14 |
| Fixing | 14 |
| Water supply connection | 15 |
| Drain connection | 15 |
| Distillate outlet pipe fitting | 15 |
| Drip tray | 16 |
| Fitting heaters | 16, 17 |
| Electrical connection | 18 |
| Reservoir connection | 19 |
| Thermal cut-out | 20 |
| Thermistor | 20 |
| Electrical controls | 21, 22 |
| Operation | 23 |
| Tap feed model | 23, 24 |
| Pre-treated feed model | 25, 26, 27 |
| Cleaning | 28, 29, 30 |
| Converting for pre-treated feed | 31, 32, 33 |
| Flow schematics | 34, 35, 36, 37 |
| Troubleshooting guide | 38 |
| Electrical schematic | 39 |
| Technical characteristics | 40 |
| Replacement parts | 41 |

Fig. 1 8 LITRE TAP FEED MODEL A56220-857LS & A56228-857LS

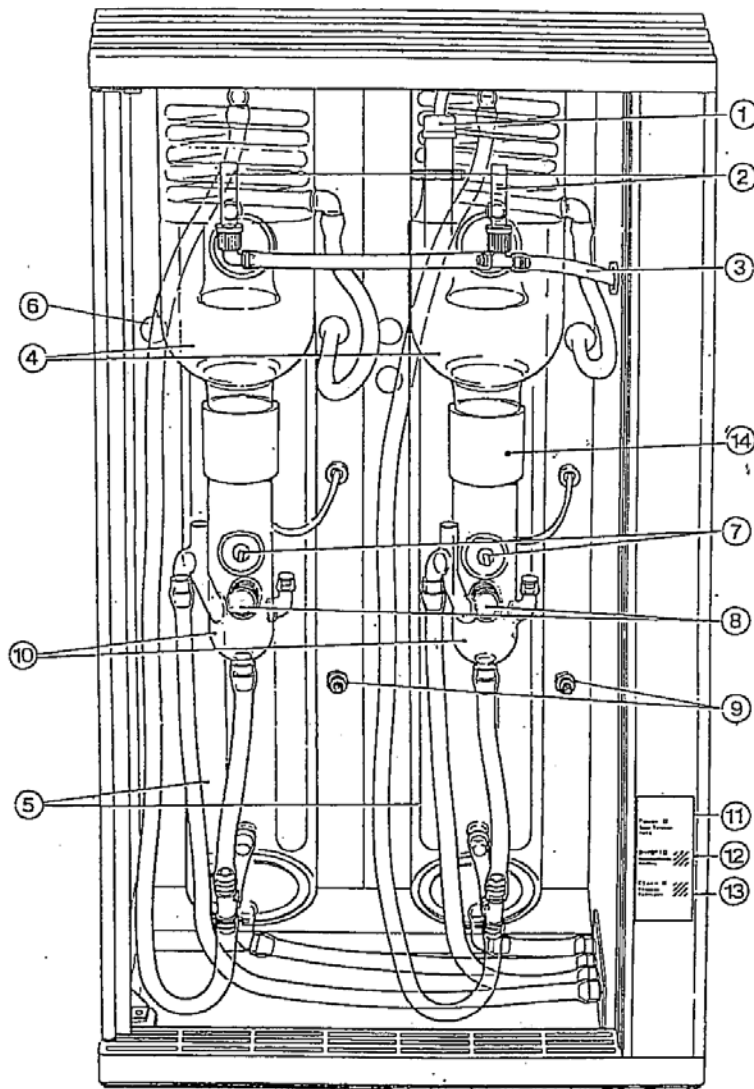

| Item | Description | Item | Description |
|------|---------------------------------|------|------------------------------|
| 1 | Heating element | 9 | Thermal cut-out reset button |
| 2 | Condenser CO ₂ bleed | 10 | Constant level device |
| 3 | Distillate tube | 11 | "Power On" lamp |
| 4 | Condenser | 12 | "On/off" membrane switch |
| 5 | Boiler | 13 | "Clean" membrane switch |
| 6 | Blanking plug | 14 | Support tubing |
| 7 | Thermistor | | |
| 8 | Thermal cut-out | | |

Fig. 1A

8 LITRE PRE-TREATED MODEL A56220-857LS & A56228-857LS

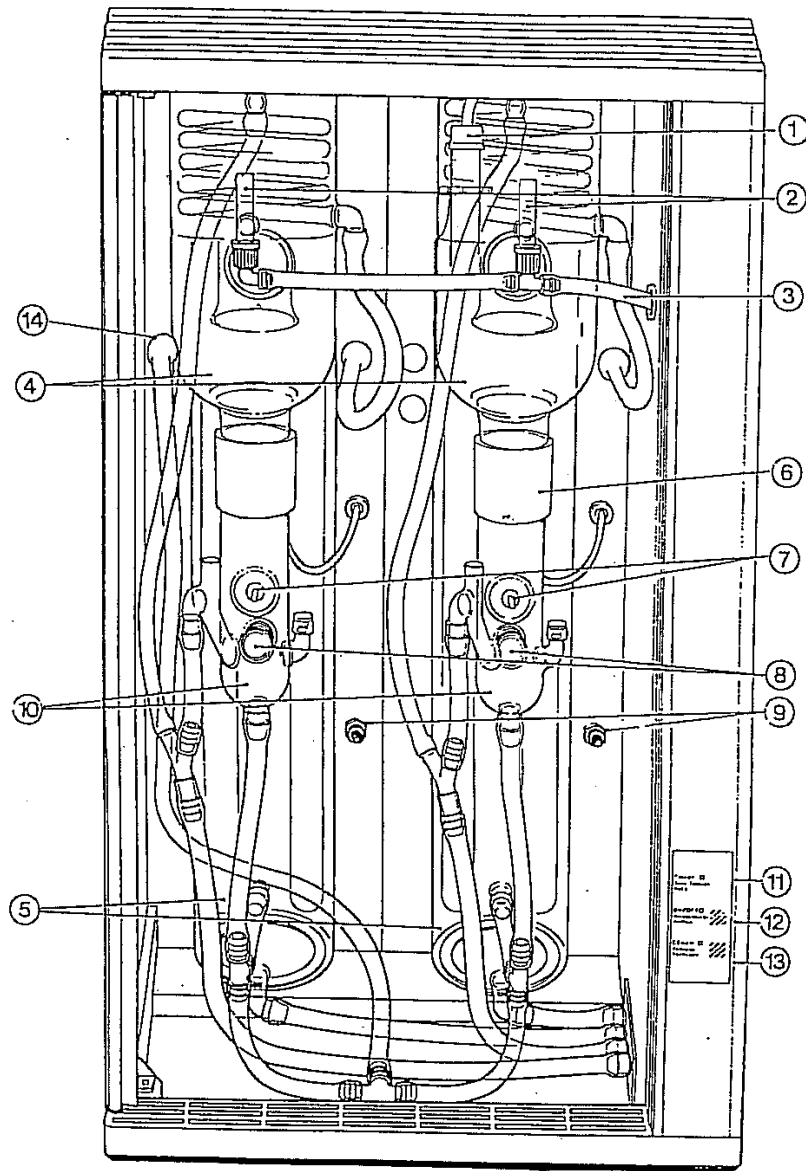

| Item | Description | Item | Description |
|------|---------------------------------|------|------------------------------|
| 1 | Heating element | 9 | Thermal cut-out reset button |
| 2 | Condenser CO ₂ bleed | 10 | Constant level device |
| 3 | Distillate tube | 11 | "Power On" lamp |
| 4 | Condenser | 12 | "On/off" membrane switch |
| 5 | Boiler | 13 | "Clean" membrane switch |
| 6 | Support tubing | 14 | Pre-treated feed input tube |
| 7 | Thermistor | | |
| 8 | Thermal cut-out | | |

Fig. 2

4BD TAP FEED MODEL A56230-857LS & A56238-857LS

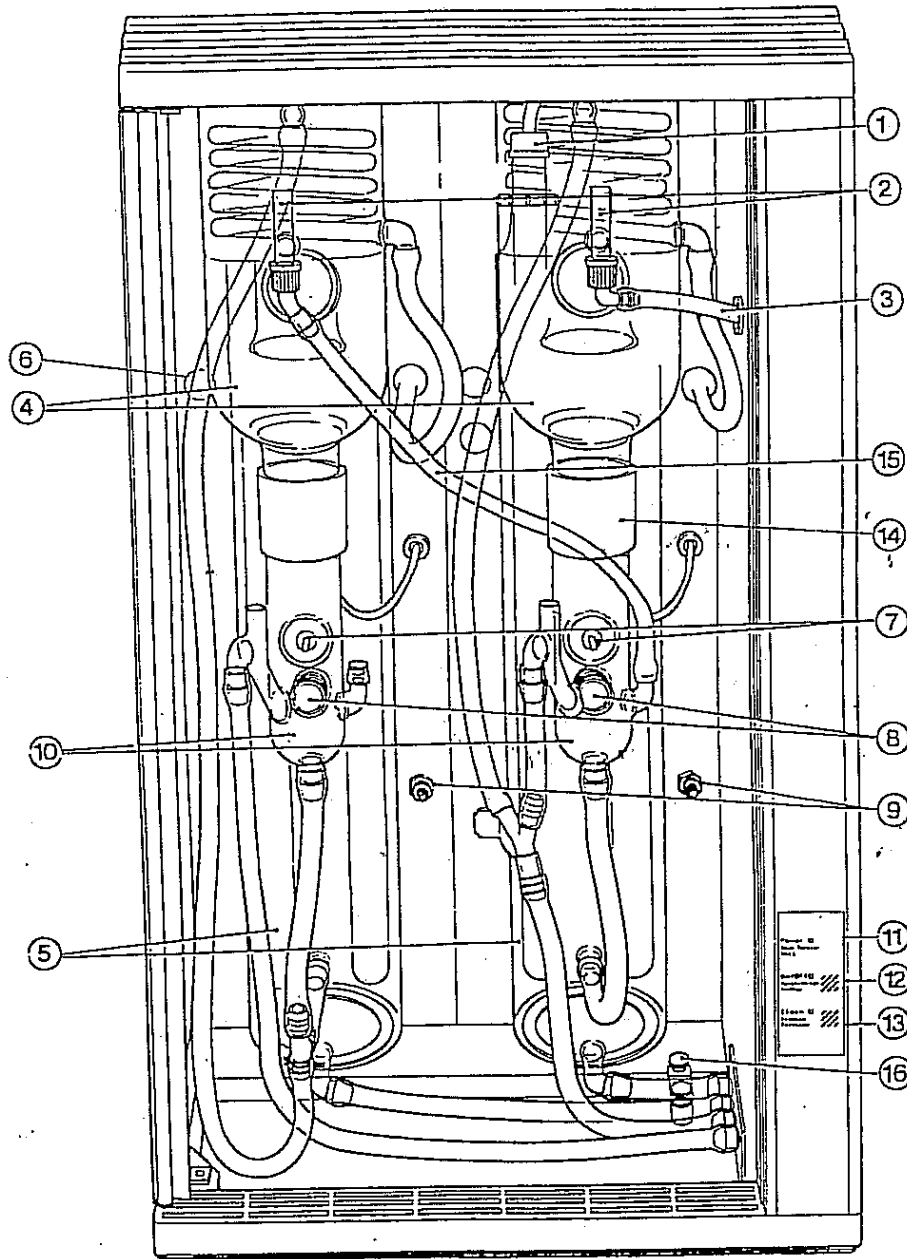

| Item | Description | Item | Description |
|------|---------------------------------|------|----------------------------------|
| 1 | Heating element | 9 | Thermal cut-out reset button |
| 2 | Condenser CO ₂ bleed | 10 | Constant level device |
| 3 | Distillate tube | 11 | "Power On" lamp |
| 4 | Condenser | 12 | "On/off" membrane switch |
| 5 | Boiler | 13 | "Clean" membrane switch |
| 6 | Blanking plug | 14 | Support tubing |
| 7 | Thermistor | 15 | Primary distillate transfer tube |
| 8 | Thermal cut-out | 16 | Boiler drain clamp |

Fig. 2A

4BD PRE-TREATED FEED MODEL A56230-857LS & A56238-857LS

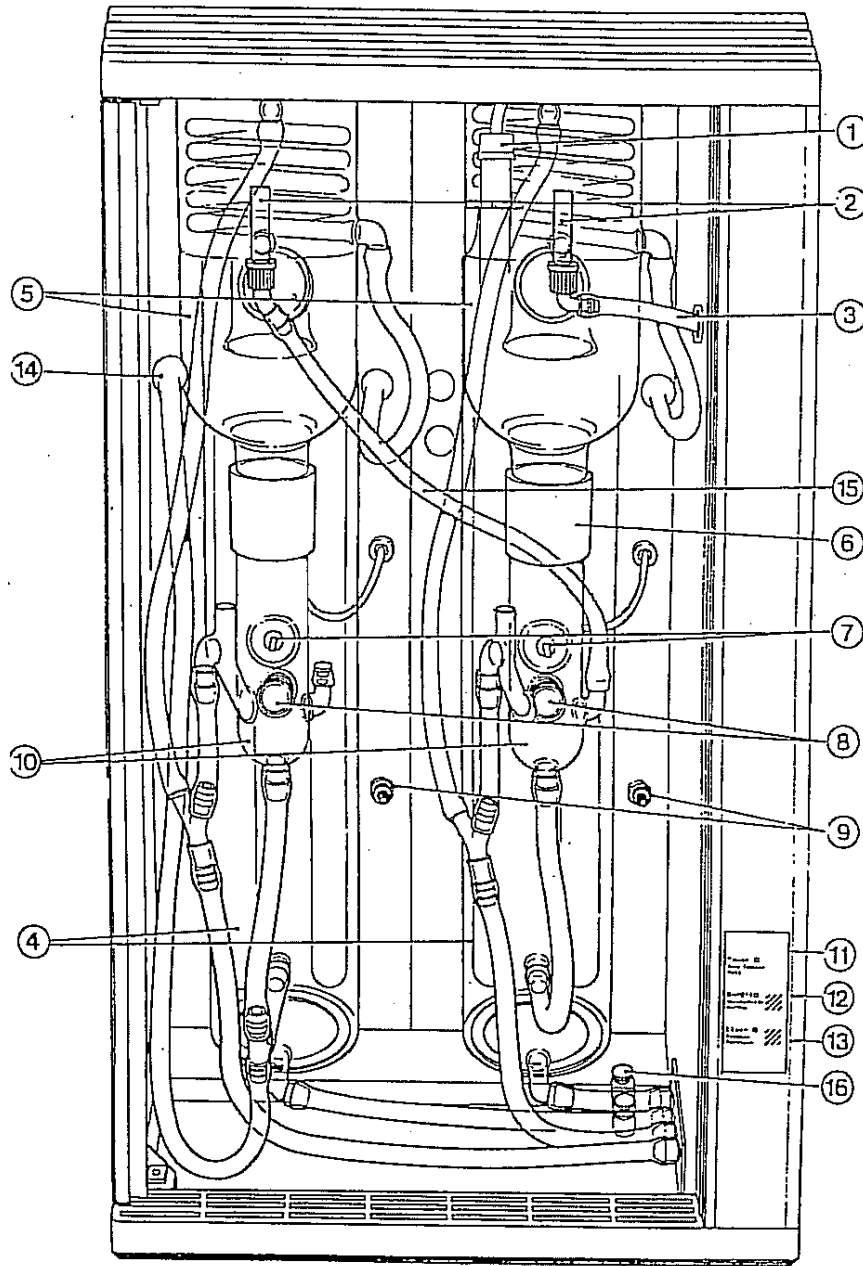

| Item | Description | Item | Description |
|------|---------------------------------|------|----------------------------------|
| 1 | Heating element | 9 | Thermal cut-out reset button |
| 2 | Condenser CO ₂ bleed | 10 | Constant level device |
| 3 | Distillate tube | 11 | "Power On" lamp |
| 4 | Condenser | 12 | "On/off" membrane switch |
| 5 | Boiler | 13 | "Clean" membrane switch |
| 6 | Support tubing | 14 | Pre-treated feed input tube |
| 7 | Thermistor | 15 | Primary distillate transfer tube |
| 8 | Thermal cut-out | 16 | Boiler drain clamp |

DESCRIPTION

The Fistreem III Glass Still is an automatic Water Still providing high grade pyrogen free distilled water. Its unique cyclonic effect condenser vapour trap eliminates any vapour borne droplets in the distillate, ensuring distilled water of the very highest quality.

The Still is only designed for the distillation of water.

Fistreem III 8, produces 8 litres per hour single distilled water.

Fistreem III 4BD, produces 4 litres per hour of double distilled water.

These instructions describe the installation and operation of the tap feed versions and instructions on how to convert to a pre-treated feed version, if required. For users wishing to supply the Still with pre-treated water (reverse osmosis, deionized, etc) see section dealing with the pre-treated feed version.

The Still is designed to be used on water pressures between 10 and 80 psig (70-560 kPa). In order to provide an optimum flow through the condensers and to avoid water wastage, the Still is fitted with a flow controller in the condenser feed pipe.

CARE OF PRODUCT

The product is finished in epoxy paint for durability. In order to keep the paint surface clean and free of stains, regular wiping with a mild detergent is recommended. Avoid the use of solvents and coarse materials.

GLASSWARE SAFETY

Like all laboratory glassware assemblies, after an extended period of use, Water Stills may suffer a reduction in wall thickness caused by the continual process of solution attrition.

In the unlikely event that failure occurs it may be sudden, therefore, it is wise to be cautious when servicing or handling equipment and also to periodically check the thickness of the Still's boiler.

.It is important to site Water Stills in a safe location such that personnel are not endangered by the spillage of boiling water or broken glass.

In operation it is strongly recommended the door on Fistream III is kept in place. By doing so, any spillage of water or failure of the glassware is likely to be contained in the Still's cabinet.

ELECTRICAL SAFETY

Before connecting this apparatus to the electricity supply, check the information given on the rating plate and ensure that:

- a) Your supply is single phase a.c. (alternating current) of the stated frequency with the neutral, nominally at earth potential.
- b) Your supply voltage is within the stated range.
- c) The current rating is within the capacity of your supply outlet.

**WARNING:
THIS APPARATUS MUST BE EARTHED.**

Consult a qualified electrician if in any doubt or if the supply system has any of the following:

- * No earth.
- * Colour code different from specified.
- * Reversible plugs.
- * Supply and return leads that are both above earth potential.

See section "Electrical Connection" for installation advice.

PRE-INSTALLATION

Before starting to install and operate your Fistream III, please read this section carefully and observe the following points:

Service Requirements

Power: The Still is factory set to one of the following voltages:

208 Volts
240 Volts

The Still will function at both 50/60Hz. Ensure that the Power supply is rated at a minimum of 30 Amps. The power input for the Still is 6 kW.

WARNING:

CHECK THAT THE VOLTAGE DESCRIBED ON THE RATING LABEL CONFORMS TO THE POWER SUPPLY YOU HAVE AVAILABLE.

ALSO CHECK THAT THE VOLTAGE MARKED ON THE HEATERS IS COMPATIBLE.

CONTACT YOUR DEALER IF THE VOLTAGES DO NOT MATCH OR YOU ARE UNSURE AS TO THEIR SUITABILITY.

Feed Water Supply: Flow should be at least 2 litres/min, at a pressure of 10-80 psig (70-560kPa).

Pre-treated Supply: If your Still uses pre-treated water, the flow rate should exceed 10 litres per.hour.

Drain: Sink or open drain to be sited below the level of the Still drain outlet. The drain should be vented to the atmosphere.

POSITIONING

It is recommended the Still is located within easy distance of services (feed water, drain water, and electrical supply) to avoid unnecessary long runs of pipework or cabling.

Environmental Conditions

The Still is designed to operate safely under the following environmental conditions:

- indoor use.
- altitude up to 2000M.
- ambient temperatures between 5°C - 40°C
- supply voltages not exceeding $\pm 10\%$ of the nominal voltage.
- maximum humidity, 80% at 31°C, decreasing linearly to 50%RH at 40°C.
- pollution degree 2.

UNPACKING

Caution: **The Still, although not particularly heavy, is an awkward size, it is recommended that at least two people are involved in all lifting operations.**

When lifting keep the door in place, any other face of the Still can be used to obtain a hold on the Still.

Carefully remove the Still and the accessory pack from the box. Inspect for breaks and missing parts

The accessory pack contains the following:

Reinforced mains input tube with fittings.
Reinforced drain tube with fittings.
Distillate tube (silicone rubber).
Distillate glass elbow.
Reservoir float level switch.
Plastic funnel.
Wall mounting bracket.
Pack to convert to pre-treated feed

NOTE: Do not dispose of any packaging until the Still is fully functioning.

INTERNAL PACKING

- a. In order to remove the internal packing and subsequently fit the heating elements it is necessary to remove the top moulded cover of the Still.
- b. Remove the door. Using a cross-head screwdriver, unscrew the two screws recessed in the holes at the front of the cover, push the cover back and lift off.
- c. Remove the white foam packing pieces from the unit.
- d. Lift out the two internal foam packing pieces from the top of the unit.

INSTALLATION PROCEDURES

Door removal

To remove the front door of the Still insert a finger in the top and bottom holes. Lift the door and pull the bottom of the door forwards.

Fixing

The Still may be either free standing or wall mounted. Where bench mounted, ensure the drain tube is allowed a continual downward path to drain, free of any restrictions.

Wall Fixing

Fix the "J" shaped mounting bracket (accessory pack) to the wall using an adequate wall anchoring method. Check the wall construction and select the most appropriate wall plug. Note the operational weight of the unit is approximately 40 kg (88 lbs).

Caution: **Contact your building maintenance personnel if you are unsure about either the type of hardware fixings to use or the ability of the wall to support this weight.**

Water Supply Connection

Connect the water input hose to the rear screw thread connector on the right side of the Still.

Ensure that the internal screen filter is installed in between the male and female parts of the screw connection.



Drain Connection

Fit the Drain hose to the front screw thread connector on the right side of the Still, uncoil and run to an open drain, sink or gully; cut to length if required. Ensure this hose is free of kinks and has an unrestricted gravity flow to drain.



It is advisable to run the drain hose below the mains water input hose to avoid any raising of the drain hose, as it exits the Still.

Distillate outlet pipe fitting

8 Litre Single Distil Model

Take the right angled glass distillate connector and fit the short piece of distillate tube (silicon tubing) to the riffled end. Connect this using the plastic screw fitting attached to the screw thread outlet of the left-hand condenser, ensure that the PTFE disc on the sealing washer is facing outwards (towards the water).

Connect this to one arm of the glass "T" piece, to the other arm connect the longer piece of distillate tube. Connect the remaining arm, using the plastic screw fitting attached, to the screw thread outlet of the right-hand condenser, ensure that the PTFE disc on the sealing washer is facing outwards (towards the water). Feed the distillate tube through the distillate port on the right side-ofthe Still. If required this may alternatively be fed through the left-hand side.

4 Litre Bi-Distillation Model

Take the right angled glass distillate connector and fit the distillate tube (silicon tubing) to the riffled end. Connect this using the plastic screw fitting attached to the screw thread outlet of the right-hand condenser, ensure that the PTFE disc on the sealing washer is facing outwards (towards the water). Feed the distillate tube through the distillate port on the right side of the Still. If required this may alternatively be fed through the left-hand side, be particularly careful, in this instance, to avoid sags in the tube.

Fig 3

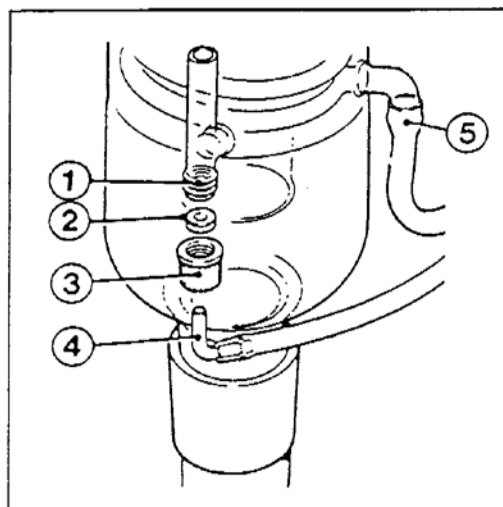

| Index | Description |
|-------|-----------------------------|
| 1. | Condenser distillate outlet |
| 2. | PTFE disc |
| 3. | Screw fitting |
| 4. | Glass distillate connector |
| 5. | Condenser feed tube |

Drip Tray

The base of the Still serves as a built-in drip/spillage tray. This will accommodate a full boiler and constant level device contents, in the event of breakage.

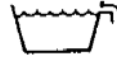

Water spillage is discharged through the small outlet sited adjacent to the water inlet connection. A suitable tube may be attached to this outlet to safely drain away any excess spillage.

FITTING HEATERS

WARNING:

ENSURE THE STILL IS DISCONNECTED FROM THE POWER SUPPLY. THIS PROCEDURE IS NOT A USER TASK AND MUST BE PERFORMED BY A QUALIFIED ELECTRICIAN OR SIMILARLY COMPETENT PERSON.

CAUTION: Ensure that the heaters are the correct rating for your Still by comparing the markings on the heater with those on the rating label.

- a) Remove the electrical access panel on the right side of the Still by removing the four retaining screws.

WARNING:

AN EARTH ELECTRICAL LEAD IS ATTACHED TO THIS PANEL. DO NOT REMOVE THIS LEAD.

Left-Hand Boiler

- b) The two identical heating elements are fitted into the top of each boiler by means of plastic screw threaded unions.
- c) Unscrew and remove from the heater the internally threaded part of the plastic union and the split ring.
- d) Push the internally threaded part of the plastic union initially onto the right side heater entry port, followed by the split ring.
- e) Insert the heater into the entry port and thread the two halves of the plastic union together until hand tight.

Fig 4

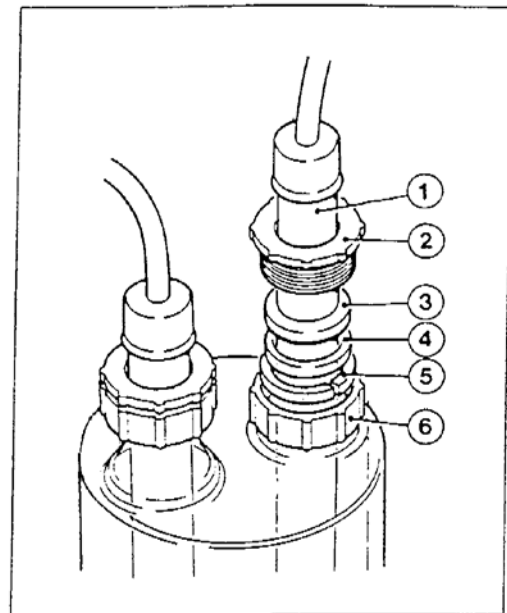

| Index | Description |
|-------|----------------------------|
| 1. | Heating element |
| 2. | Plastic union (heater) |
| 3. | Nitrile rubber ring |
| 4. | Heater entry port (boiler) |
| 5. | Split ring |
| 6. | Plastics union (boiler) |

NOTE: A smear of silicone grease on the tapered surface of the nitrile rubber ring and on the union threads greatly assists obtaining a tight joint.

To avoid nuisance tripping of the thermal cut-out it is important to equally space the heaters from the boiler wall and the glass pocket of the thermal cut-out. This may be achieved by rotating the heater prior to fully tightening the plastic unions.

- f) The heater cable should be fed through the slot in the rear of the boiler compartment and be secured by means of the cable restraining grommet.

Repeat this procedure (b-f) for the other heater (left side of the boiler).

- g) Feed both heater cables through the retaining clip and allow sufficient cable for connection to relay A, (fig 4).

NOTE: The wires of the heater are terminated with different connectors, this allows you to connect one wire from each heater to a terminal. The colours of the wire and their orientation onto the relay are unimportant.

NOTE: This is a good time to check that the heater core is fully located at the bottom of its sheath.

- h) To avoid any excess cable, adjust the restraining grommets to allow surplus cable to be fed behind the boiler bulkhead panel.

Right-Hand Boiler

- i) Repeat this procedure (b-h) for the right-hand boiler, but connect the heater cables to Relay B.
- j) Refit the electrical compartment access panel **ENSURING THE EARTH WIRE IS CONNECTED** and that screws are fully tightened.
- k) Re-fit the top moulding.
- l) Re-fit the door.

Fig 5

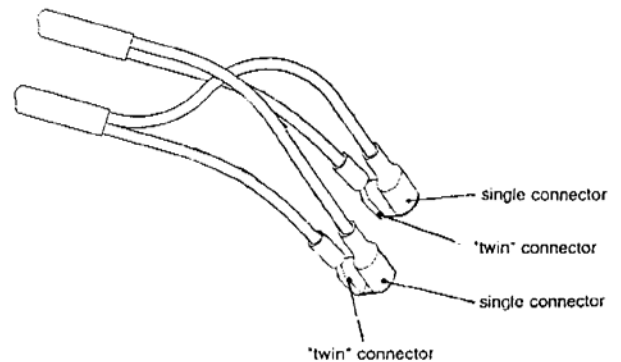
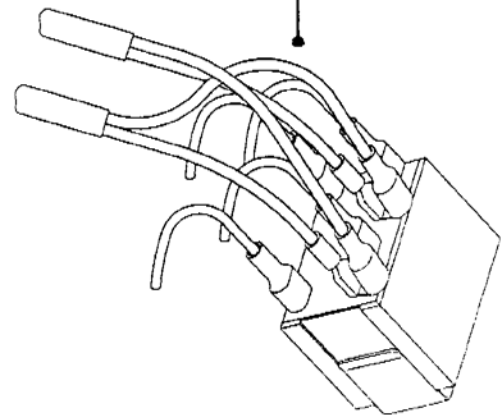
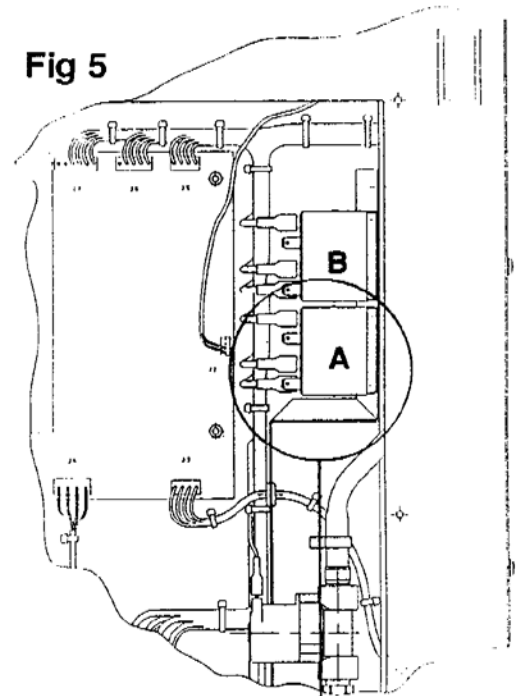

ELECTRICAL CONNECTION

WARNING:

THIS PROCEDURE IS NOT A USER TASK AND MUST BE PERFORMED BY A QUALIFIED ELECTRICIAN.

Both the 8 litre and 4 litre Bi-distillers require connection in accordance your local Electrical installation regulations.

It is recommended that the following (if their use conforms to your local' regulations) are used for the installation:

- a. Switchbox or isolator with a specification of safely handling at least 30 Amps. It should switch both phases. Both phases should be fused with integral fuse elements of 30 Amp rupture value.
- b. The switch box or isolator should be located within 2 metres of the Still, easily accessible for isolation as required and be unambiguously marked.
- c. The cable connects in the Still using the terminals marked L and N for the relevant Lines. Earth is connected using a suitable connector to the earth post marked with the symbol.
- d. Cable size should be 8 AWG



WARNING:

THIS APPARATUS MUST BE EARTHED.

1. **Introduce screwdriver into the operating slot up to the stop.**
2. **Hold clamping spring open with the screwdriver so that the conductor can be inserted into the clamping unit.**
3. **Withdraw the screwdriver to clamp the conductor.**

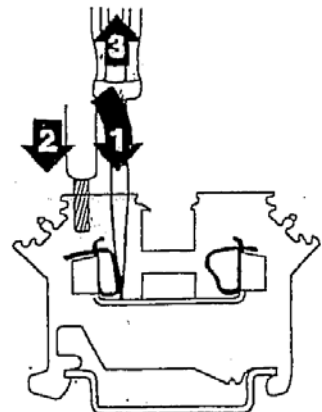

RESERVOIR CONNECTION

The Still is supplied with a reservoir float level switch (accessory pack). The float switch allows the Still to be used with a reservoir of the user's choice.

- a) Push the reservoir float switch plug into the connector and lock into position.
- b) Choose a suitable container and insert the float switch in a vertical mode ensuring it is secured firmly into position. A locking nut is provided for this purpose and should be used where possible. (1/2" (12.5 mm)) diameter hole for float switch).

The orientation of the float switch is shown in Fig 6. Whenever removing, the float from the float switch stem it is important the float, when refitted, is positioned correctly (note the embossed "T", for top) otherwise the switch will not function.

The Still will now automatically switch on and off as the reservoir fills and empties.

To prevent frequent switching of the Still the float has a wide switching differential, hence the long stem.



Fig 6

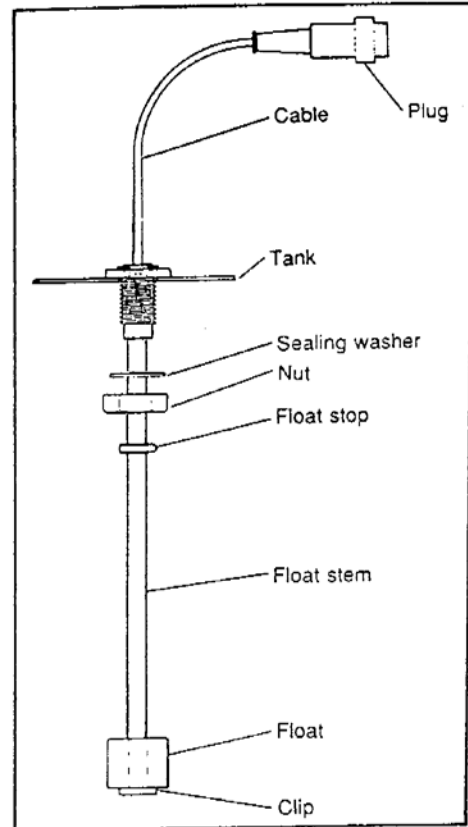

THERMAL CUT-OUT

A thermal cut-out, Fig 1 (8) is fitted to the boiler to protect the Still from overheating, in the unlikely event that other controls fail. The thermal cut-out is resettable by the user.

Should the thermal cut-out operate, all function indicators on the membrane switch panel will extinguish, but the green mains "power on" lamp on the right side of the Still will remain lit.

- a) Leave the Still to cool for approximately 20 minutes before resetting.
- b) To reset the cut-out, firmly push in the reset button, Fig 1 (9).
- c) The Still should now operate normally.
- d) Should the cut-out operate again, call for a Service Engineer.

THERMISTOR

A thermistor sensor is installed in the rear of the constant level device, Fig 1 (7).

In the event of the thermistor requiring replacement:

- a) Ensure that the Still is disconnected from the electricity supply.
- b) Remove the electrical control panel on the right of the Still.
- c) Disconnect the thermistor leads from the printed circuit board.
- d) Pull the cables out through the front of the Still, this is easier if the back panel is removed.
- e) Peel off the thermistor boot assembly and pull out the assembly from the constant level device, this can require a twisting/pulling action.
- f) The reverse procedure is required for fitting the replacement. A slight smear of grease on the boot will greatly assist refitting.

BEFORE PROCEEDING TO THE "OPERATION" SECTION, PLEASE FAMILIARIZE YOURSELF WITH THE ELECTRICAL FUNCTIONS OF THE STILL. THESE ARE DESCRIBED AS FOLLOWS:

ELECTRICAL CONTROLS

Indicator Lamps

Three LED lamps on the membrane switch panel indicate the following functions:

POWER Coloured Green. This indicates the presence of power to the unit. It is lit whenever power is available in the logic circuits.

ON/OFF Coloured Yellow. Shows power is available to the heaters. It does not necessarily indicate that the heaters are on. Separate sensors (eg. thermistor, reservoir float switch) will determine when the heaters are switched on and off.

CLEAN Coloured Yellow. Indicates the unit is in its clean cycle.

Membrane Switches

Two membrane switches have the following functions:

ON/OFF This is used in both the distilled cycle and the clean cycle.

CLEAN This is used to select the clean mode. It may only be used when the unit is in "idle" mode, i.e. when both "on/off" and "clean" lamps are extinguished.

L.E.D. Displays

The unit operates in a number of different modes. These modes can be understood by interpreting the combinations of the LED displays. The following table shows the different modes together with the action taken if one or other switch is pressed.

| | |
|-------------|---|
| IDLE mode | “on/off” and “clean” LED’s are both Unlit. System is idle awaiting instruction. Press “on/off” to enter DISTIL mode Press “clean” to enter CLEAN mode |
| DISTIL mode | “on/off” LED lit, “clean” LED unlit System is distilling normally Press “on/off” to return to IDLE mode |
| CLEAN mode | “Clean” LED lit, “on/off” LED unlit System is in clean mode and will not discharge water from the boiler Press “clean” to return to IDLE mode Press “on/off” to select HEAT mode |
| HEAT mode | “Clean” and “on/off” LED’s both lit. System is in clean mode and will fill the boiler (if not already full) and then switch the heaters ON for a controlled period of time. |

If the unit is in DISTIL mode and the distillate water tank is full the “on/off” lamp will flash to indicate this and the heaters will turn off. The boilers will not drain.

If any of the LED’s are flashing, this indicates that the self Check has found a fault and is advising the user.

OPERATION

Normal operation of this Still does not involve the user with any of the internal workings of the unit.

In operation it is strongly recommended the door on Fistream III is kept in place. By doing so, any spillage of water or failure of the glassware is likely to be contained in the Stills cabinet. It also prevents the user from accidentally touching the hot glassware inside.

WARNING:

UNDER NO CIRCUMSTANCES SHOULD ANY OF THE ACCESS PANELS BE REMOVED WHEN THE STILL IS IN USE OR WHILE THE POWER-ON LAMP IS ILLUMINATED.

SERVICING SHOULD ONLY BE UNDERTAKEN BY QUALIFIED PERSONNEL

INITIAL SETTING UP AND NORMAL OPERATION

TAP FEED VERSION

- a) Connect the Still to a suitable power supply (see "ELECTRICAL" section) and switch on at the wall power outlet.
- b) Check that the green "SUPPLY ON" lamp at the right side of the unit is illuminated.
- c) On applying power, the Still will undertake a short electrical function check, this is indicated by a flashing "power" LED. After 20 seconds self check is complete and the LED will stop flashing.
- d) Ensure the drain tube is sited correctly and that the distillate tube is placed into a suitable container (see also under section "Reservoir Connection")
- e) Turn on the mains water supply and check for leaks.
- f) Press the "on/off" membrane switch. This will bring the Still into "Distil" mode.

The "on/off" lamp will illuminate and water will begin to flow through the system.

NORMAL OPERATION FUNCTION

TAP FEED VERSION

8 litre per hour Still

Water will enter both constant level devices and boilers. When water covers the thermistors in the constant level devices, the heaters will switch on. After approximately five minutes water will boil and distillate will begin to flow.

Discard the first ten minutes of distillate production in order to flush from the system any transportation/ packaging dust.

To switch off the unit, press the "on/off" or "clean" membrane switch. Water will automatically drain from the glassware.

4 Bi-Distiller

Water will enter the left-hand constant level device and boiler. When water covers the thermistor in the constant level device, the heaters will switch on. After approximately five minutes water will boil and distillate will begin to flow. This then begins to fill the right-hand constant level device and boiler, when full this boiler also begins to heat.

Discard the first ten minutes of distillate production in order to flush from the system any transportation/ packaging dust.

To switch off the unit, press the "on/off" or "clean" membrane switch. Water will automatically drain from the glassware.

Note: The 4BD Bi-distiller model has a clamp fitted to the drain pipe of the right-hand boiler to prevent it wasting pure water when the Still is in the clean mode.

PRE-TREATED FEED VERSION

INTRODUCTION

Models are supplied complete with all the necessary components and tubing to allow the user to feed both pre-treated and tap water.

The Still may be supplied with water produced by deionization, distillation or reverse osmosis. Alternatively, the Fistreem III pre-treatment system is specifically designed to provide a suitable source of pre-treated water.

Condenser water (tap water) is used as cooling water and is diverted to drain. Boiler water (pre-treated) is only used as make-up water. The Still has built in controls to regulate the flow of treated water and avoid waste.

If you have a new Still, or wish to convert to pre-treated feed please refer to the section in these instructions "To convert the Still to pre-treated feed" before proceeding.

CAUTION:

Normal operation of this Still does not involve the user with any of the internal workings of the Still.

In operation it is strongly recommended that the door on Fistreem III is kept in place. By doing so, any spillage of water or failure of the glassware is likely to be contained in the Still's cabinet. It also prevents the user from accidentally touching the hot glassware inside.

WARNING:

UNDER NO CIRCUMSTANCES SHOULD ANY OF THE ACCESS PANELS BE REMOVED WHEN THE STILL IS IN USE OR WHILE THE POWER-ON LAMP IS ILLUMINATED.

SERVICING SHOULD ONLY BE UNDERTAKEN BY QUALIFIED PERSONNEL

INITIAL SETTING UP (PRE-TREATED FEED MODE)

External connections from a user's existing pre-treated feed supply

- a) Connect the pre-treated water feed supply to the water input Fig. 2 (14) using the angled hose connector supplied.
- b) Turn on the treated water supply. Check for leaks.

NOTE: The treated water must have a positive pressure, although a very low pressure (2 psig) is acceptable.

OPERATION

- a) Ensure the drain tube is sited into an open drain, sink or gulley.
- b) Check that the distillate tube is placed into a suitable container.
- c) Connect-the Still to a suitable power supply (see "ELECTRICAL" section) and switch on at the wall power outlet.
- d) Check the green "supply on" lamp on the right side of the unit is illuminated.
- e) On applying power, the Still will undertake a short electrical function check, indicated by the "power" LED flashing.
- f) Connect the mains tap water input to a suitable supply and turn on the mains supply. Check for leaks.
- g) Turn-on the pre-treated water supply. Check for leaks.
- h) Press the "on/off" membrane switch. This will bring the Still into "Distil" mode. The "on/off" lamp will illuminate and pre-treated water will flow into both the boiler and constant level device.

When the thermistor has been covered, signifying that the boiler is full, the heaters will switch on and cooling water will flow through the condenser. The cooling water will continue to flow until the Still returns to the idle mode or the power is switched off.

The treated water supply will be automatically controlled into the boiler to prevent wastage.

- i) It is advisable to discard the first ten minutes of distillate in order to flush any transportation packaging dust from the system.

To switch off the unit, press the "on/off" or "clean" membrane switch.

NOTE: When the Still is switched off the boiler contents will not be discharged to drain if the Still is in pre-treat mode.

MAINTENANCE

Periodic inspection of connecting hoses, internal tubings, connections and glassware parts is recommended to ensure continuity of safe operation and avoiding unnecessary leaks.

User should inspect any replacement parts to ensure they are manufacturer specified parts.

CLEANING

When the Still is run on raw tap water, routine de-scaling may be necessary. In hard water areas regular cleaning will prevent excessive scale build-up and allow efficient trouble free running.

On the 4BD Bi-distiller model it is unlikely that the right-hand boiler will require de-scaling.

Whenever suitable quality treated feed water is fed to the Still, de-scaling of the Still's boiler will rarely, if ever, be necessary. However, where low grade treated water has been used, after an extended period de-scaling may become necessary.

To clean the Still follow this procedure

- a. Allow the Still to cool before cleaning.
- b. Remove the acrylic door.
- c. Turn the mains water supply on at the tap.
Users with the pre-treated feed model should also turn on the 'treated ' water supply.
- d. Switch the power supply on at the wall socket and ensure both the "on/off" and "clean" lamps are unlit. The "power" LED will flash whilst the Still completes its self check routine.
- e. Press the "clean" membrane switch to initiate the cleaning cycle. The "clean" lamp will illuminate.
The drain discharge valve is now closed and the cleaning agent may be introduced.

CAUTION:

The use of hydrochloric acid is recommended. Other substances such as hydrofluoric acid and similar highly aggressive acids should be avoided as these may cause premature failure of the Still.

Consult the manufacturer or dealer if there is any doubt as to the compatibility of the cleaning or decontamination agent with parts of the equipment.

Care should be taken to avoid inhalation of any injurious or poisonous fumes being liberated from the cleaning agent during the de-scaling operation. – See also under Ventilation

WARNING:

WHEN HANDLING HYDROCHLORIC ACID ALWAYS USE PROTECTIVE GLOVES, CLOTHES AND GLASSES.

IN THE EVENT OF ACCIDENTAL ACID SPILLAGE IT IS WISE TO IMMEDIATELY REMOVE THIS HAZARD BY DILUTING THE SPILLAGE WITH COPIOUS AMOUNTS OF CLEAN TAP WATER AND REMOVING WITH SUITABLE CLEANING CLOTH.

Ventilation

Ensure there is adequate ventilation in the immediate Area during the de-scaling process when using strong acids such as hydrochloric acid.

- f. Fill a beaker with 100 ml of tap water and add 100 ml of concentrated hydrochloric acid (30% - 36 % w/v).

WARNING:

NEVER ADD THE WATER TO THE ACID

- g. Carefully pour the acid solution into the orifice at the top of the constant level device Fig 7, using the plastic funnel provided (accessory pack).

CAUTION:

If excessive acid has been used or if the boiler is particularly heavily scaled, considerable foaming may occur.

In extreme circumstances foaming may reach the condenser. It may be difficult to remove this deposit from the condenser (dismantling of the glassware will be necessary) to avoid this condition press the "clean" membrane switch to drain the boiler.

Repeat the cleaning procedure using a more dilute solution of hydrochloric acid.

Fig 7

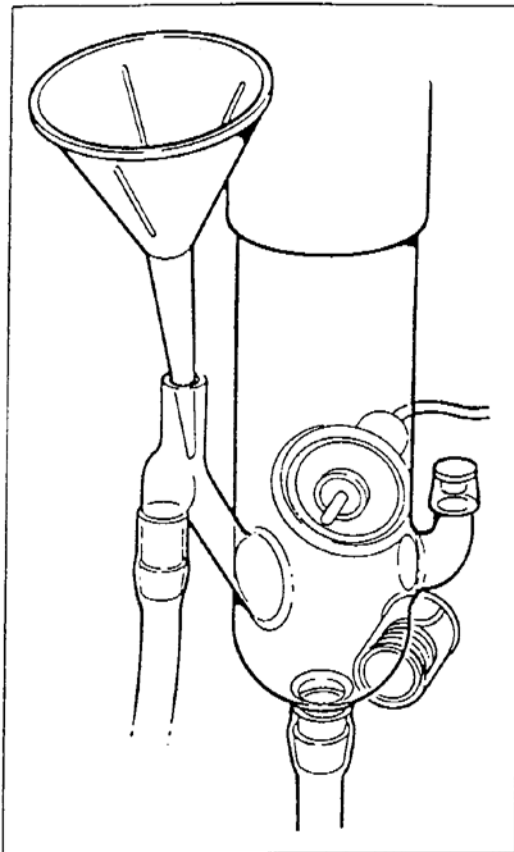

- h. Press the "on/off" switch. The "on/off" lamp will illuminate and tap water will be introduced into the boiler.

When the boiler is full, the heaters will automatically switch on for a period of 90 seconds. This will warm the dilute acid solution and improve the efficiency of the cleaning.

- i. When the heating period of 90 seconds expires, the heaters will switch off and the "on/off" lamp will extinguish.

The solution will remain in the boiler and the "clean" lamp will remain illuminated. The unit may now be left to soak for a period to allow the solution to have maximum effect.

- j. When the glassware is clean the solution may be discharged and the boilers rinsed by pressing the "clean" membrane switch. This consists of two rinses, before returning to the idle mode ("clean" lamp extinguished).

- k. Should any scale remain on the glassware below the normal water levels, the cleaning cycle may be repeated.

Any-scale formed above the normal water level is unlikely to be removed by this cleaning process. However, since such scale will not be detrimental to the Still's operation or distillate quality it can be disregarded.

The unit will now be in the 'Idle' mode.

This operation will need duplicating in 8 litre versions (i.e. both boilers).

In the 4 BD the right-hand boiler should not require any de-scaling.

TO CONVERT THE STILL FOR PRE-TREATED FEED

WARNING

UNDER NO CIRCUMSTANCES SHOULD ANY OF THE ACCESS PANELS BE REMOVED WHEN THE STILL IS IN USE OR WHILE THE "POWER ON" LAMP IS ILLUMINATED.

SERVICING SHOULD ONLY BE UNDERTAKEN BY QUALIFIED PERSONNEL

Introduction

By utilising the Pre-treated feed components (in accessory pack), the user can upgrade the Fistream III Water Still to run on purified water supplies. This supply can be deionised, distilled or reverse osmosis water from an existing supply.

Condenser cooling water (tap feed) is separated from the boiler supply (purified) for economy. The controls in the Still regulate the purified water to minimise waste.

Pre-treated feed components (accessory pack)

Supply tube
T-piece (needed for 8 litre version)
2 x Condenser drain tubes (fitted with Y-piece)
Ty-wraps
Black rubber grommet

4BD PRE-TREATED FEED VERSION

- a) Remove the rear panel of the Still.
- b) Identify the treated water inlet solenoid valve (bottom right) see Fig 8. Fit to this, the supply tube and fasten with one of the Ty-wraps (cut off the surplus tail from the Ty-wrap)
- c) Remove the blank plug. Fig 2 (6) and fit the grommet into the vacated hole
- d) Feed the supply tube through this hole ensuring the tube is not kinked and any surplus is through to the front of the Still, Fig 9 (1).

Fig 8

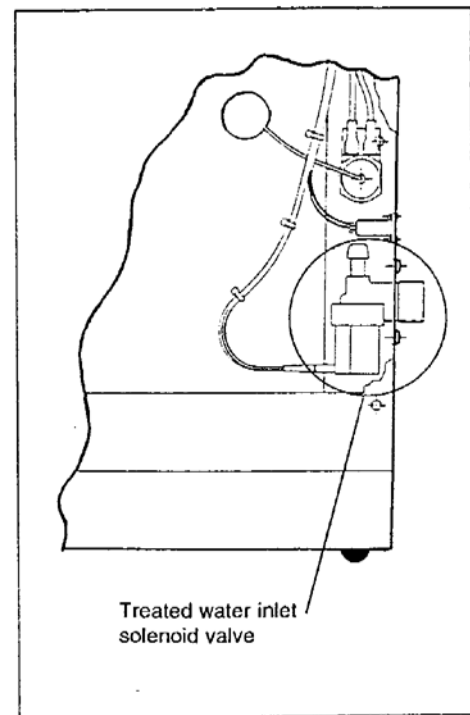

- e) Refit the rear panel.
- f) Cut the constant level device drain tube, of the left hand boiler, approximately 95mm beneath the overflow. Attach this to one leg of the Y-piece and the other cut end to the stem of the Y-piece Fig 9 (2).
- g) Cut the condenser drain tube, so that it may be connected to the remaining leg of the Y-piece. This will allow the condenser to empty directly to drain. Remove the rest of this tube from the left hand T-piece Fig 9 (3).
- h) The supply tube from the inlet solenoid valve can now be connected to the T-piece, Fig 9 (3), cut this to length, if required. This allows the treated water to flow into the boiler.

Fig 9

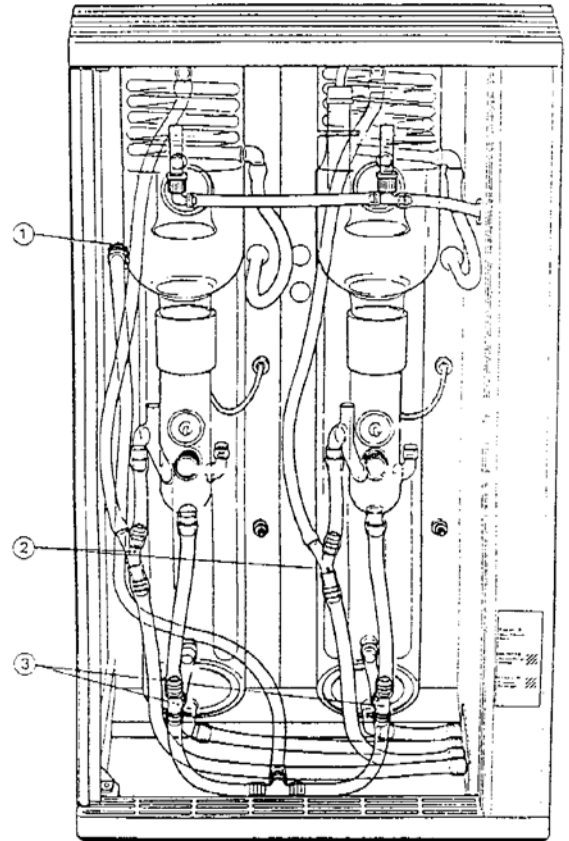

The Still's tubing arrangement is now correct for pre-treated feed operation.

Finally, the control section, needs modifying:

- i) Remove the side panel.

WARNING:
AN EARTH ELECTRICAL LEAD
IS ATTACHED TO THIS PANEL

DO NOT REMOVE THIS LEAD

- j) Identify the "DIL" switches on the main control board.

Alter them from this (Tap Feed):

- 1 = closed
- 2 = closed
- 3 = open
- 4 = open

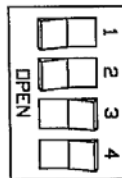

DIL SWITCH ARRANGEMENT
 FOR CYCLON MK III 4 LTR/BD
 TAP FEED VARIANT STILLS

To this (Treated Feed):

- 1 = open
- 2 = open
- 3 = closed
- 4 = open

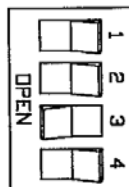

DIL SWITCH ARRANGEMENT
 FOR CYCLON MK III 4 LTR/BD
 DI FEED VARIANT STILLS

- k) Replace side panel

8 LITRE PRE-TREATED FEED VERSION

- a) Remove the rear panel of the Still.
- b) Identify the treated water inlet solenoid valve (bottom right) see Fig 8 . Fit to this, the supply tube and fasten with one of the Ty-wraps (cut off the surplus tail from the Ty-wrap)
- c) Remove the blank plug. Fig 1 (6) and fit the grommet into the vacated hole.
- d) Feed the supply tube through this hole ensuring the tube is not kinked and any surplus is through to the front of the Still, Fig 9 (1).
- e) Refit the rear panel.
- f) Cut the constant level device drain tube of the left hand boiler, approximately 95mm beneath the overflow. Attach this to one leg of the Y-piece and the other cut end to the stem of the Y-piece, Fig 9 (2).
- g) Cut the condenser drain tube so that it may be connected to the remaining leg of the Y-piece. This will allow the condenser to empty directly to drain. Remove the rest of this tube from the left hand T-piece, Fig 9(3).
- h) Repeat 6. and 7. for the right hand boiler.
- i) The supply tube from the inlet solenoid valve, -itself fitted to a T-piece (see Fig 1A), can now be connected to the two original T-pieces, cut this to length, if required. This allows the treated water to flow into both boilers.

The Still's tubing arrangement is now correct for pre-treated feed operation.

Finally, the control section, needs modifying:

j) Remove the side panel

WARNING:
AN EARTH ELECTRICAL LEAD
IS ATTACHED TO THIS PANEL
DO NOT REMOVE THIS LEAD

k) Identify the "DIL" switches on the main control board. Alter them to read ;

Alter them from this (Tap Feed):

- 1 = closed
- 2 = open
- 3 = closed
- 4 = open

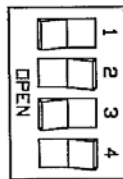

DIL SWITCH ARRANGEMENT
FOR CYCLON MK III 8 LTR
TAP FEED VARIANT STILLS

To this (Treated Feed):

- 1 = open
- 2 = closed
- 3 = closed
- 4 = open

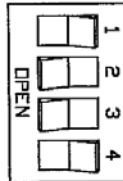

DIL SWITCH ARRANGEMENT
FOR CYCLON MK III 8 LTR
DI FEED VARIANT STILLS

l) Replace side panel

**FLOW DIAGRAM FOR OPERATION OF THE FISTREEM III STILL
8 LITRE TAP FEED MODEL A56220-857LS & A56228-857LS**

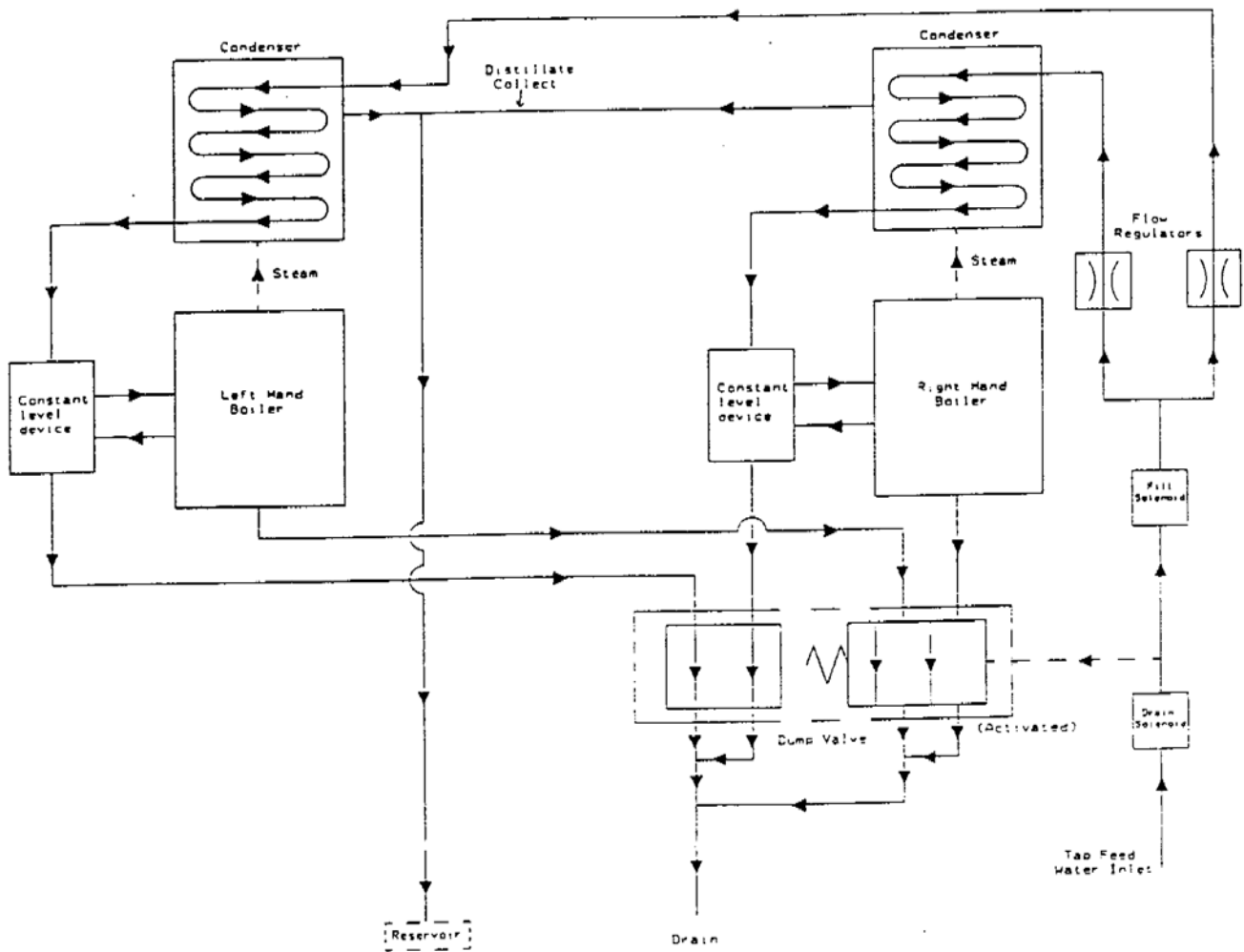

**FLOW DIAGRAM FOR OPERATION OF THE FISTREEM III STILL
8 LITRE PRE-TREATED FEED MODEL A56220-857LS & A56228-857LS**

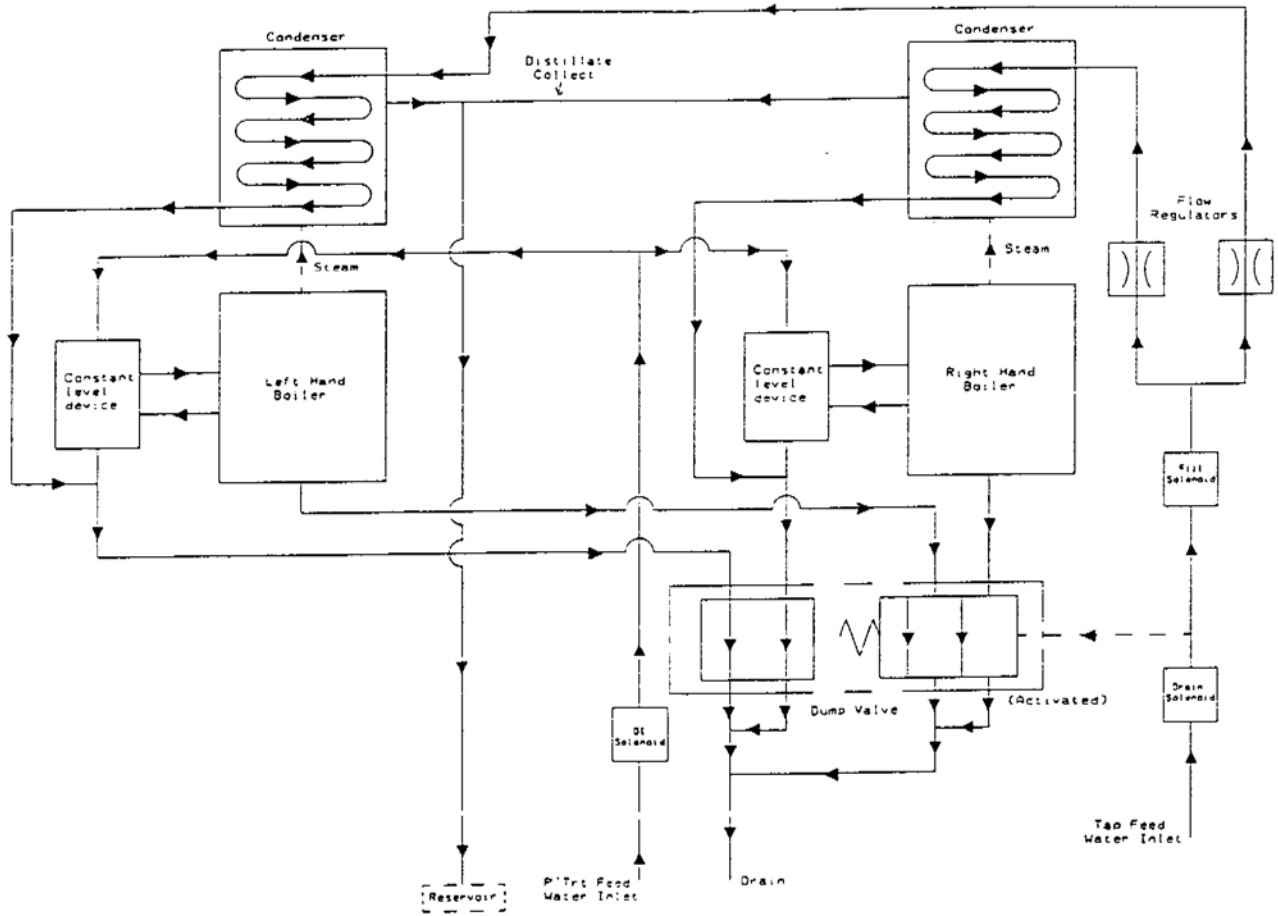

**FLOW DIAGRAM FOR OPERATION OF THE FISTREEM III STILL
4BD TAP FEED MODEL A56230-857LS & A56238-857LS**

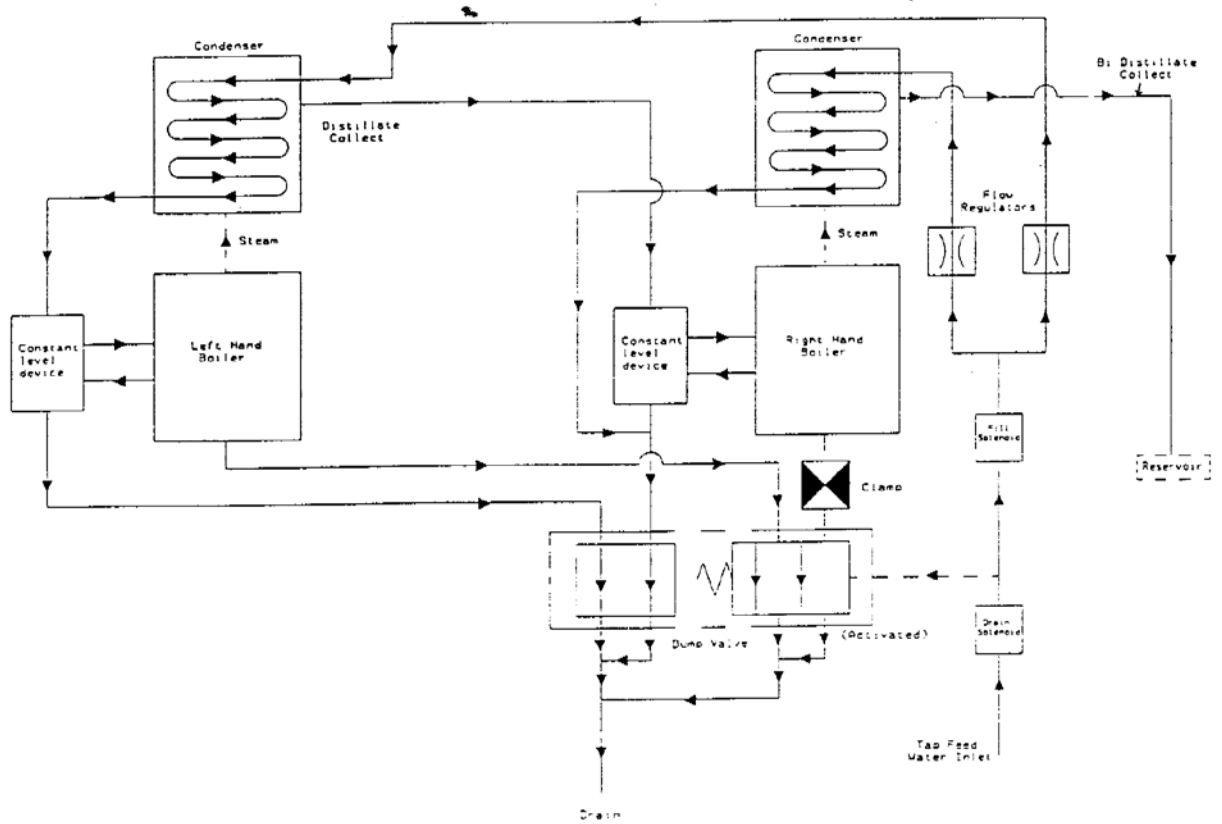

**FLOW DIAGRAM FOR OPERATION OF THE FISTREAM III STILL
4BD PRE-TREATED FEED MODEL A56230-857LS & A56238-857LS**

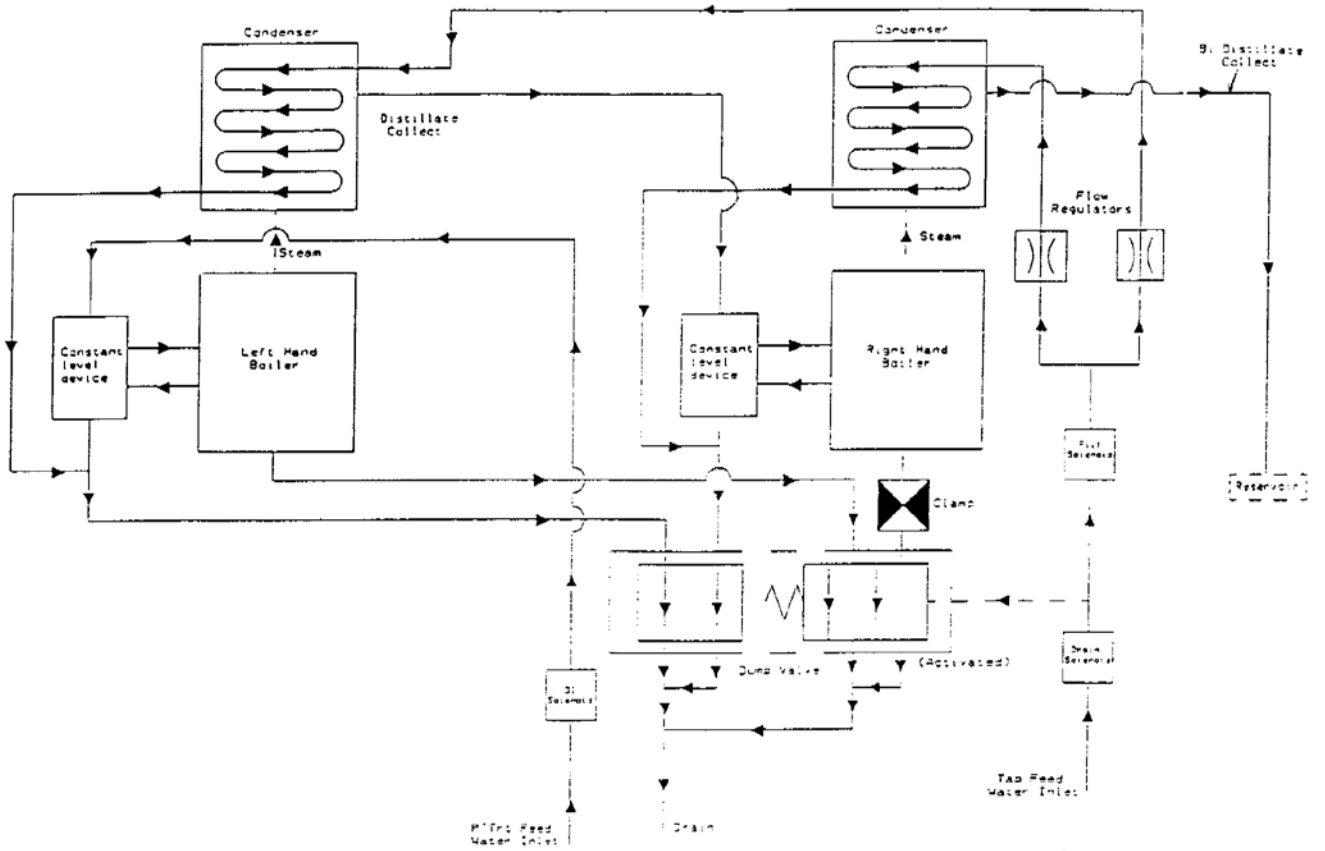

TROUBLESHOOTING GUIDE

WARNING MANY OF THE FOLLOWING PROCEDURES SHOULD ONLY BE ATTEMPTED BY A QUALIFIED ELECTRICIAN

| SYMPTOM | PROBABLE CAUSE | TEST & REMEDY |
|---|---|--|
| System inoperative and no water flows. | Power failure, check circuit breaker or fuse panel, | Power failure, verify unit is connected to electrical services. |
| No indicator lights illuminated. | Faulty power switch. | Check continuity. Replace/rewire switch. |
| "On/off" lamp flashes. | Tank full No water flow | No fault See symptoms describing no water |
| Continuous audible alarm. | Reservoir float switch either connected or disconnected during distil cycle. | Switch off, connect float switch, then restart. |
| 10 second audible alarm, then both "power" and "on/off" indicators flash. | Thermistor exposed for too long a period during start-up. | Identify reasons for lack of water in constant level device. |
| 10 second audible alarm, then both "power" and "Clean" indicators flash. | Thermistor exposed during distil cycle. | Identify reasons for lack of water in constant level device. |
| "Mains" indicator on, but "power" indicator off. | Internal fuse blown; LED failed; faulty controller board; faulty transformer. | Identify faulty component and rectify |
| Water does not boil or there is insufficient boiling. | Thermal cut-out tripped. Faulty heater(s) | Allow the hot system to cool (about 10 minutes). Then reset the thermal cut-out. Check heater continuity, if open circuit, then replace. |
| Low cooling water flow or no flow at all. | Feedwater valve (faucet) closed. Low feed pressure. Blocked feed line or clogged filter in connector. Blocked flow controller. Faulty inlet solenoid valve. | Open valve. Check for minimum 10 psi feed pressure. Remove & inspect feed pipe/solenoid screen for obstruction. Clean or replace. Clean by removing and backflushing or replace. Replace solenoid. |
| Distillate output low (also see insufficient boiling, above). | Faulty heater(s). Supply voltage low. | Check heater continuity, if open circuit, then replace. Check voltage and rating plate requirements. |
| Boiler overfills or water overflows at the constant level device. | Blocked drain tube. | Inspect water pathway from boiler to drain. Check pipes are not kinked or blocked. Ensure the drain tube is below the level of the boiler. |
| Low boiler water level (also check low cooling water symptoms). | Blockage in distillate or vent tubes. Pre-treated feed solenoid valve failed. | Inspect for obstruction. Check valve operation, replace if required. |
| Distillate build up in condenser. | Kinked or blocked distillate tube. Excessive flow resistance. | Inspect and eliminate bends or blockages in the pipe. Check free flow of distillate in the outlet tube to the reservoir. |
| Boiler fails to discharge contents | Dump valve seized or blocked. Loss of power. Scale blocking drain pathway. | Repair or replace. Restore power as appropriate. Remove scale by either chemical or physical means. |

ELECTRICAL SCHEMATIC OF THE 8 LT & 4BD FISTREEM III STILL

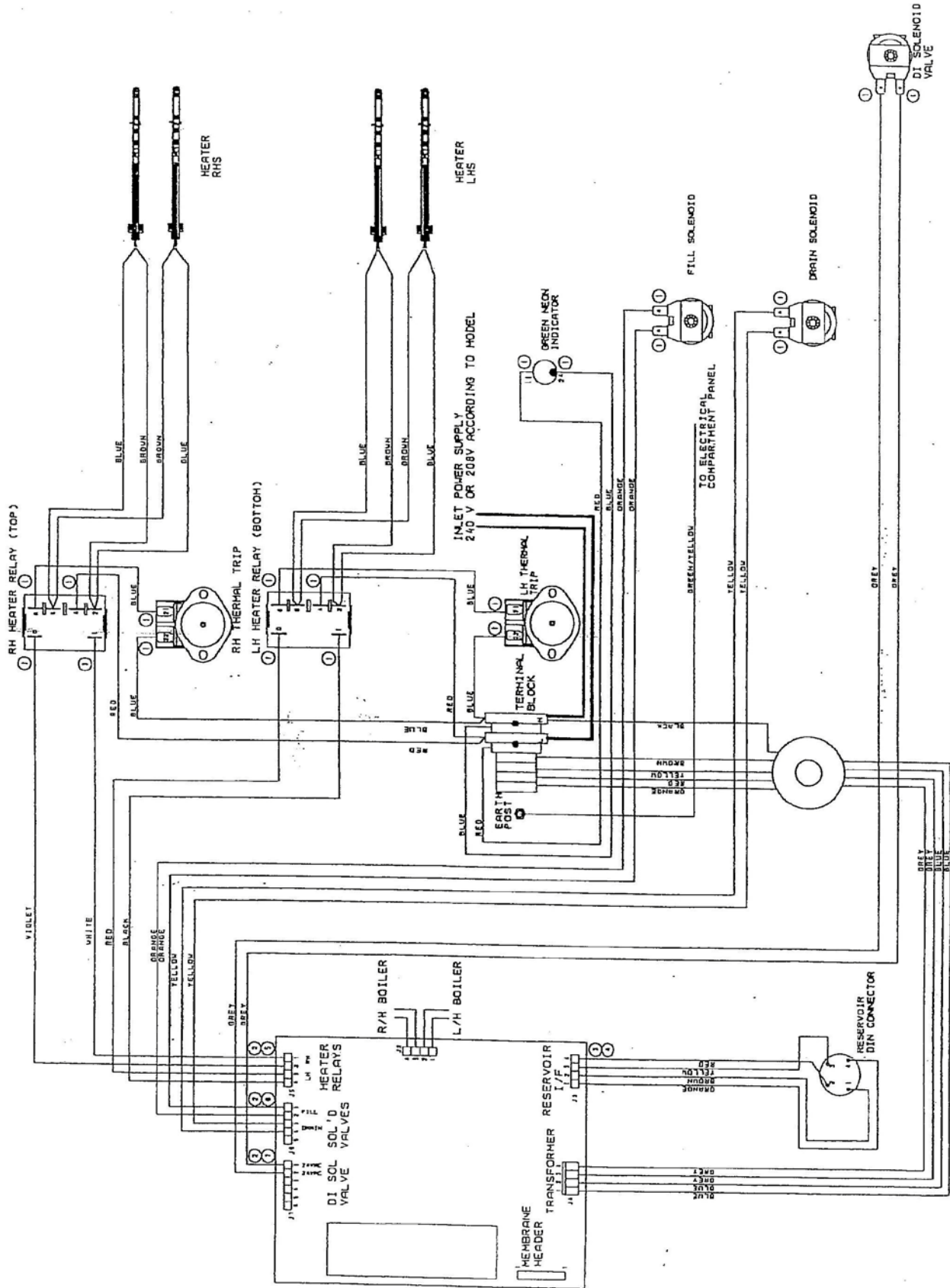

TECHNICAL CHARACTERISTICS

Feed water requirements

| | |
|-------------------------------|--|
| Tap water | 10 - 80 psig (70 - 560 kPa) |
| Treated water (optional) | more than 10 litres/hour more than 2 psig |
| Operational temperature range | 4° - 47°C (40° - 120°F) |
| Cooling water temperature | 4° - 30°C (40° - 86°F) |

Dimensions and weight

| | |
|--------------------|-------|
| Width | 490mm |
| Depth | 380mm |
| Height | 750mm |
| Operational weight | 40Kg |

Plumbing connections

| | |
|------------------|----------------------------|
| Feed water inlet | ½ " (12.5 mm) ID tubing. |
| Drain outlet | ½ " (12.5 mm) ID tubing |

Electrical requirement (depending on model supplied)

- 208V 50-60Hz single phase 30 amp fused.
- 240V 50-60Hz single phase 30 amp fused.

Check the equipment rating label for details

If your power supply is different from the rated unit, please contact your supplier or local dealer.



LabStrong Corp.
7709 Commerce Park
Dubuque
IA 52002
U.S.A.

Phone: 563-588-8900
www.labstrong.com